

Report type-examination

Report belonging to type-examination certificate number	: NL16-400-1002-196-03
Date of issue of original certificate	: 22-11-2016
Certificate applies to	: Component
Revision number / date	: 4, 08-06-2021
Requirements	: Lifts Directive 2014/33/EU Parts of standards: EN 81-21:2018, EN 81-20:2020, EN 131-2:2010+A1:2012, EN 131-2:2010+A2:2017 clause 5.2 only for L260A, L315A and L340A, made out of aluminum
Project number	: P160225-01, P170103-01, P180084, P180295, P210188

1. General specifications

Description of the product	: Foldable pit ladder Type 3A/ pit ladder Type 2A and 2B
Trademark	: OKATT
Type no.	: Slim ladder L050, L100, L200, L260, L300, L315, L340, L400, L4000, L260A, L315A, L340A, B050, B100, B200, B300 and B400
Name and address of the manufacturer	: TALLERES AGUI, S.A. Poligono Industrial Lintzirin-Gaina. Parcela B-1, E-20180 Oiartzun Gipuzkoa, Spain
Laboratory	: ITAINNOVA C/ Maria de Luna, 7-8 50018 ZARAGOZA, Spain
Address of examined component	: C/ Maria de Luna, 7-8 50018 ZARAGOZA, Spain
Data of examination	: Aug. - Nov. 2016, Mar. 2017, Mar. 2018, Nov. - Dec. 2018, June 2021
Examination performed by	: E. Verkaik, H. Kramer

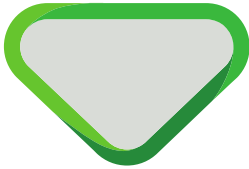

2. Description component

The Agui aluminium and steel foldable Type 3A ladders L050, L100, L200, L260, L300, L315, L340, L400 and L4000 are meant to be used as a pit ladder in a lift well. The models have three, four, five, six, seven, eight or ten steps, for a total height of 694 – 2724 mm of highest steps.

L-shaped fixation profiles must be mounted in both stiles, to be hooked into the door guide. The fixation profiles must be mounted at such a height, that the ladder can be used with an angle of 65°-70° placed against the edge of the landing sill.

An anti-tipping bar is supplied for mounting at the bottom of the pit, to inhibit lateral shifting of the ladder, where applicable.

The steps are provided with an anti-slip pattern.

The ladder can be folded by rotation points at the ends of every step.

A fixation bar keeps the ladder locked in the unfolded and folded position, by pressing a self-locking pin this bar can be unlocked.

The folded ladder is stored in the well within a wall bracket. The presence of the stored ladder is checked by a safety contact.

The ladder does have uprights which extends at least 1,10 m measured vertically above the landing sill.

To prevent that the ladder will be taken away, a chain is provided to fix the ladder in the well.

The Agui Type 2A ladders are mounted to the pit wall at top and bottom, and can be rotated downwards till they rest on the pit floor.

The Agui Type 2B ladders are mounted to the pit wall, and can be slided downwards till they rest on the pit floor.

The rest position of the stored ladder is checked by a safety contact.

GENERAL DATA TYPE 3A

Type slim ladder	Model No.	Total width in use [mm]	Total length in use [mm]	Total length folded [mm]	Highest step [mm]	Number of steps	2 or 1 part
L050	OKT15014L0	348	1845	2152	694	3	1
L100	OKT15014L1	348	2135	2442	984	4	1
L200	OKT15014L2	348	2425	2732	1274	5	1
L300	OKT15014L3	350	2815	3122	1564	6	2
L400	OKT15014L4	350	3105	3412	1854	7	2

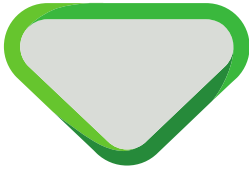

Type slim ladder	Model No.	Total width in use [mm]	Total length in use [mm]	Total length folded [mm]	Height of highest step [mm]	Number of steps	2 parts or 1 part
L260	OKT1501.5L1	350	2600	2907,5	1274	5	2
L315	OKT1501.5L2	351	3150	3457,5	1854	7	2
L340	OKT1501.5L3	351	3400	3707,5	2144	8	2
L4000	OKT1501.5L4	351	4000	4307,5	2724	10	1

Type slim ladder (aluminum)	Model No.	Total width in use [mm]	Total length in use [mm]	Total length folded [mm]	Height of highest step [mm]	Number of steps	2 parts or 1 part
L260A	OKT180731L 0560380	353,4	2600	2907,5	1274	5	1
L315A	OKT180731L 0560381	353,4	3150	3457,5	1854	7	1
L340A	OKT180731L 0560382	353,4	3400	3707,5	2144	8	1

GENERAL DATA TYPE 2A (see also Annex 1)

Model	L1 [mm]	L2 [mm]	L3 [mm]	L4 [mm]	N steps	Pit height [mm]	2 or 1 pieces	Profile	Safety switch
Mod. 1	2000	480	355	39	2	500-610	1 piece	Profile 1	1 NC/ 1 NO
Mod. 2	2000	770			3	611-900			
Mod. 3	2450	1060			4	901-1190			
Mod. 4	2450	1350			5	1191-1350			
Mod. 5	3150	1350	360	45	5	1351-1480	2 pieces		
Mod. 6	3150	1640			6	1481-1770			
Mod. 7	3150	1930			7	1771-2050			
Mod. 8	3400	2220			65	8	2050-2300		

GENERAL DATA TYPE 2B (see also Annex 1)

Type slim ladder	Model No.	Total width in use [mm]	Total length in use [mm]	Total length folded [mm]	Highest step [mm]	Number of steps	2 or 1 part
B050	OKT210101L0	348	1845	2152	694	3	1
B100	OKT210101L1	348	2135	2442	984	4	1

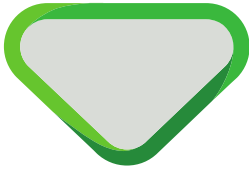

liftinstituut

SINCE 1933

B200	OKT210101L2	348	2425	2732	1274	5	1
B300	OKT210101L3	350	2815	3122	1564	6	2
B400	OKT210101L4	350	3105	3412	1854	7	2

See annex 1 for a general overview of the product.

3. Examinations and tests

The examination covered a check whether compliance with the Lift Directive 2014/33/EU is met, if possible based on the harmonized product standards EN 81-21:2018, EN 81-20:2020 and EN 131-2:2010+A1:2012. The aluminum (6063-T6) ladders have also been subjected to the EN 131-2:2010+A2:2017 clause 5.2 and passes the test.

Issues not covered by or not complying these Standards are directly related to the above mentioned essential requirements based on the risk assessment, where applicable with the aid of harmonized A-and B-standards.

The examination included:

- Examination of the technical file (See annex 2).
- Check of strength and dimension demands according to EN 81-21:2018, EN 81-20:2020, EN 131-2:2010+A1:2012 and EN 131-2:2010+A2:2017 clause 5.2 only for L260A, L315A, L340A made out of the material 6063-T6
- Examination of the representative model in order to establish conformity with the technical file.
- Inspections and tests to check compliance with the requirements.

4. Results

After the final examination the product and the technical file were found in accordance with the requirements. The functional tests passed without remarks. The strength tests passed without remarks and did fulfill the demands of EN 131-2:2010+A1:2012.

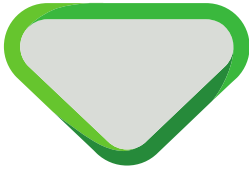

5. Conditions

Additional to or in deviation of the applicable demands in the considered requirements / standards (see certificate and/or page 1 of this report), the following conditions shall be taken into account:

Type 3A

- The L-shaped fixation profiles must be mounted at the ladder to make it able to put it at the edge of the landing sill with an angle of 65°-70°.
- With every ladder an anti-tipping bar is supplied to inhibit possible lateral shifting of the ladder. This must be mounted at the bottom of the pit where applicable.
- For storage in the well, a wall bracket must be mounted. The ladder must be stored within 800 mm of the edge of the landing entrance.
- To prevent that the ladder will be taken away, a chain is provided to fix the ladder in the well.

Type 2A

- For storage in the well, the rotation brackets must be mounted at top and bottom of the ladder. The ladder must be stored within 800 mm of the edge of the landing entrance.

Type 2B

- For storage in the well, the mounting bracket must be mounted at top of the ladder. The ladder must be stored within 800 mm of the edge of the landing entrance.

General

- The presence of the stored ladder must be checked by a safety contact in the safety circuit of the lift.

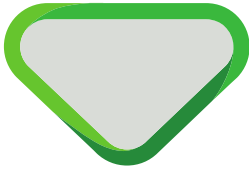

liftinstituut
SINCE 1933

6. Conclusions

Based upon the results of the type-examination Liftinstituut B.V. issues a type-examination certificate.

The type-examination certificate is only valid for products which are in conformity with the same specifications as the type certified product. The type-examination certificate is issued based on the requirements that are valid at the date of issue. In case of changes of the product specifications, changes in the requirements or changes in the state of the art the certificate holder shall request Liftinstituut B.V. to reconsider the validity of the type-examination certificate.

Prepared by:

E. Verkaik
Product Specialist Certification
Liftinstituut B.V.

Certification decision by:

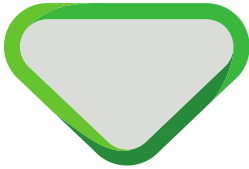

Annexes

Annex 1 : General overview of the product

LADDER TYPE 3A:



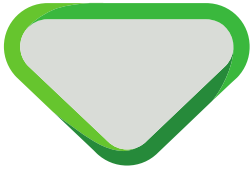

liftinstituut
SINCE 1933



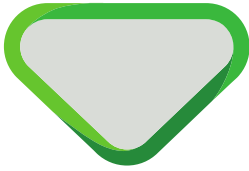

liftinstituut
SINCE 1933

DETAIL CLIP FIXING PLATE





liftinstituut
SINCE 1933

LADDER TYPE 3A:



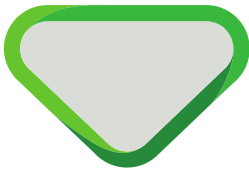

liftinstituut
SINCE 1933

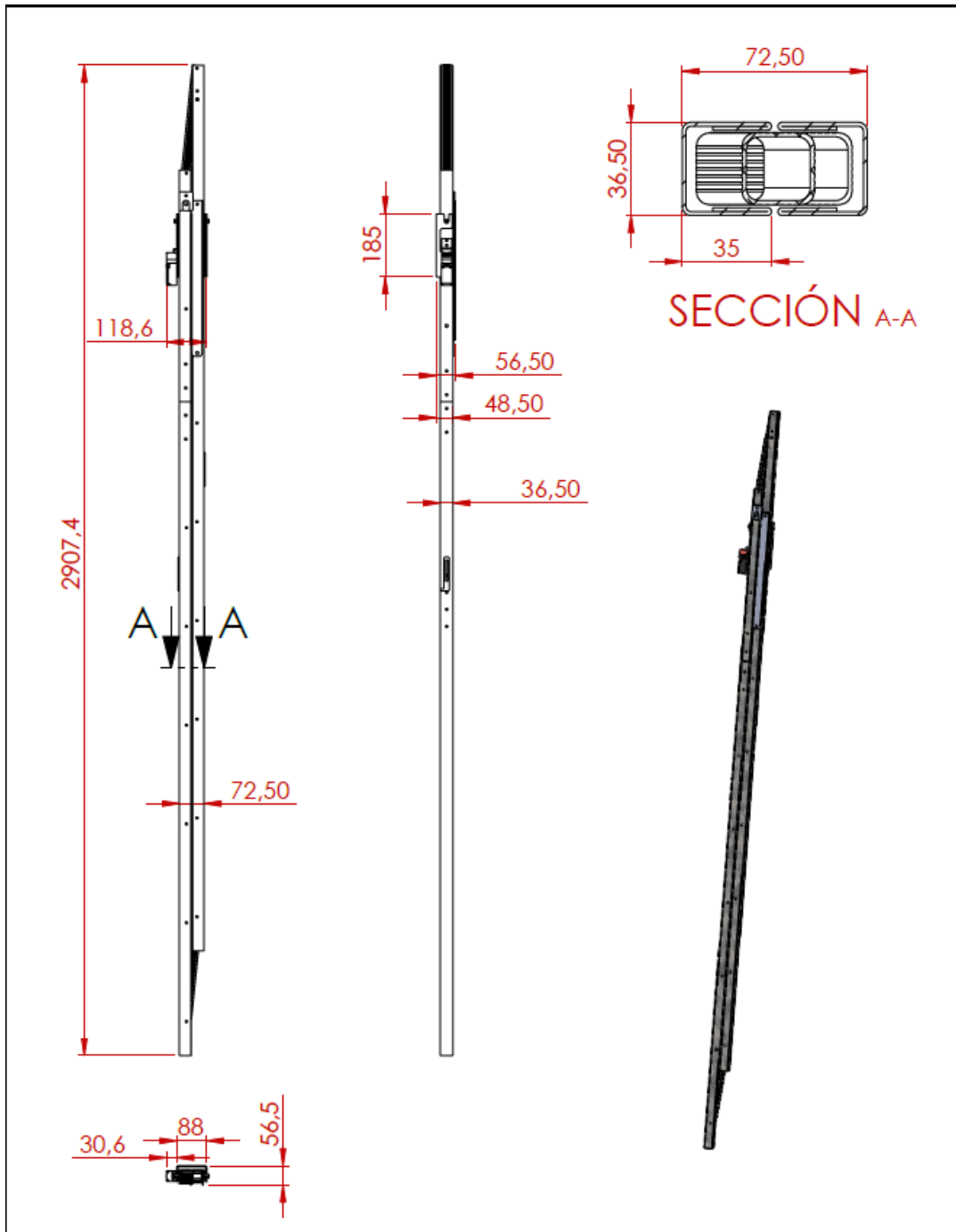

Tolerancia general mecanizado (mm)		Más de / more than hasta / up to	0,09 6	6 30	30 120	120 400	400 1000	1000 2000	MATERIAL (Material)	OKATT L2600			
General tolerance machined (mm)		=	0.1	0.2	0.3	0.5	0.8	1.2					
Tolerancia general según DNP-004 / General tolerance according to DNP-004									ACABADO (Finish)	CODIGO (Code) OKT1501.5L1			
									Nº PLANO (Drawing Nº)	OKT1501.5L			
0 EDICIÓN									DENOMINACION (Description)	OKT1501.5L			
Rev. MODIFICACIONES (Changes)									FECHA (Date)	COMP. (Appv'd)	DIB. (Drawn)	Escalera L2600	Hoja: 1 de 2

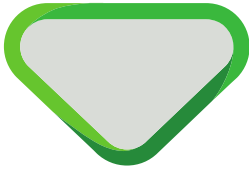

liftinstituut
SINCE 1933

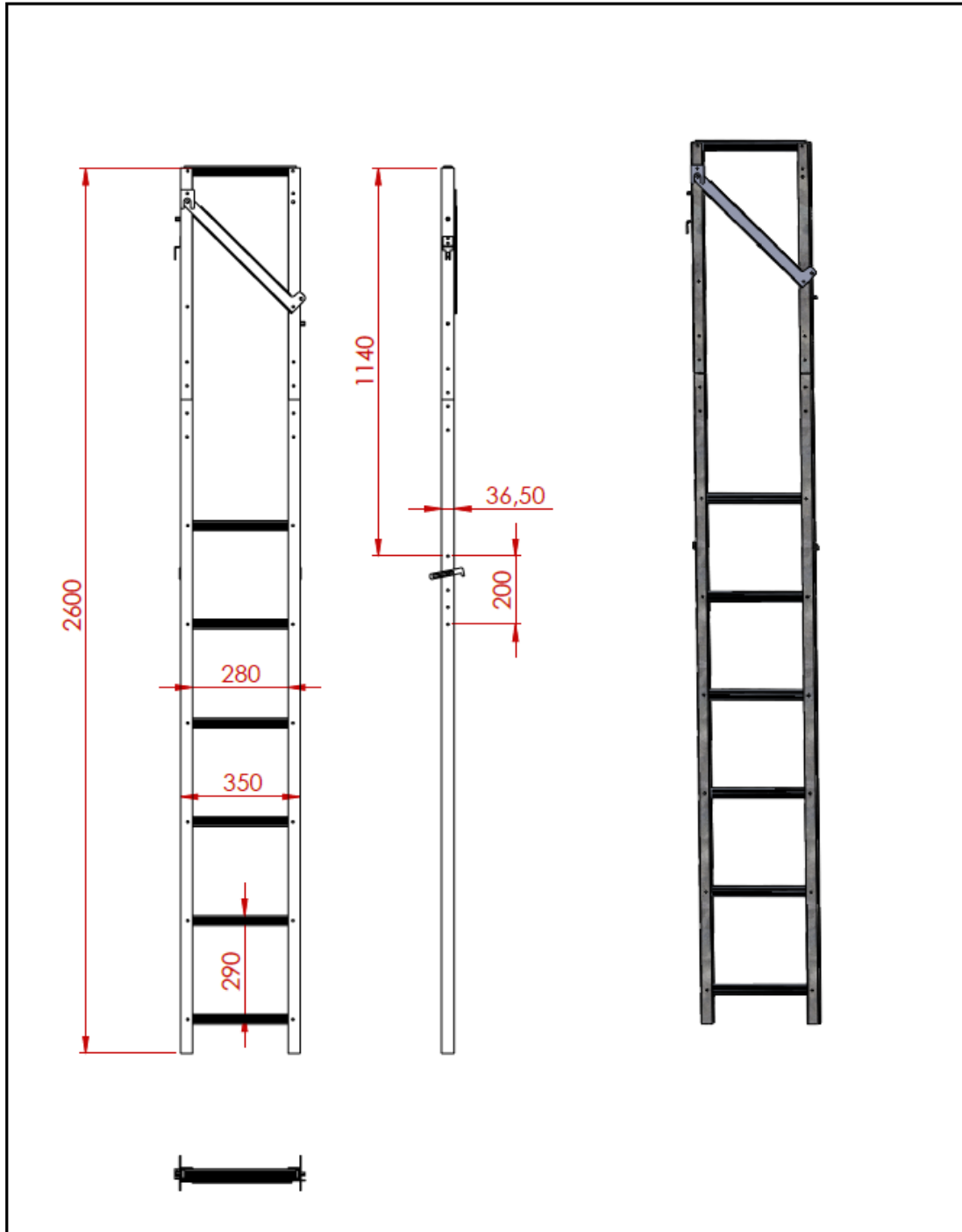

Tolerancia general mecanizado (mm) General tolerance machined (mm)		Más de / more than hasta / up to	0,09 6	6 30	30 120	120 400	400 1000	1000 2000	MATERIAL (Material) ACABADO (Finish)	 CODIGO (Code) OKT1501.5L1 Nº PLANO (Drawing Nº) OKT1501.5L Hoja : 2 de 2
		±	0.1	0.2	0.3	0.5	0.8	1.2		
Tolerancia general según DNP-004 / General tolerance according to DNP-004									DENOMINACION (Description) Escalera L2600	
0	EDICIÓN		14/03/17	J.F.	J.C.					
Rev.	MODIFICACIONES (Changes)		FECHA (Date)	COMP. (Appv'd)	DIB. (Drawn)					

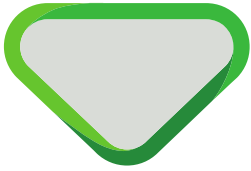

CODIGO	MODEL	A	C	E (LENGTH)	LENGTH CLOSED	F	PROFILE STEPS	N WEIGHT (Kg.)	STEPS TORQUE (Nm)	PLATE-LADDER FIXING CHAIN (M)
0560380	OKT1501-5L1	36.5	60	2600	2920	200	2	11.9	3.2	5
0560381	OKT1501-5L2	36.5	60	3150	3470	450	2	13.5	3.1	
0560382	OKT1501-5L3	50	72.5	3400	3720	200	3	13.9	2.5	
0560383	OKT1501-5L4	66	88.5	4000	4322	450	4	14.8	2.3	

ALL NUTS DIN-985 (ANTI LOOSE):
M6 GENERAL TORQUE 10Nm.* (See steps Torque in the chart)
M4 GENERAL TORQUE 3,5Nm.

Tolerancia general según DIN-984 / General tolerance according to DIN-984		ACABADO (Finish)	
EDICION		REVISIONES (Revisions)	
11/16/17 J.F.Z. E.I.G.		SLDM LADDER	
MATERIALES (Materials)		V.T.	
OKATT		OKT1501-5L	
CURSORES (Cursors)		DESCRIPCION (Description)	
9 PLANOS (Drawing 9)		ESCALA (Scale) 1:18	

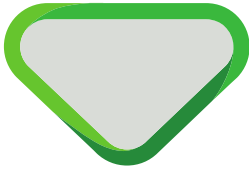

liftinstituut
SINCE 1933

CODIGO	MODEL	A	C	E (LENGTH)	LENGTH CLOSED	F	PROFILE STEPS	N WEIGHT (Kg.)	STEPS TORQUE (Nm)	PLATE-LADDER FIXING CHAIN (M)
0560380	OKT1501-5L1	36.5	60	2600	2920	200	2	11.9	3.2	5
0560381	OKT1501-5L2	36.5	60	3150	3470	450	2	13.5	3.1	
0560382	OKT1501-5L3	50	72.5	3400	3720	200	3	13.9	2.5	
0560383	OKT1501-5L4	66	88.5	4000	4322	450	4	14.8	2.3	

ALL NUTS DIN-985 (ANTI LOOSE):
M6 GENERAL TORQUE 10Nm.* (See steps Torque in the chart)
M4 GENERAL TORQUE 3.5Nm.

Tolerancia general según DIN-984 / General tolerance according to DIN-984		MATERIAL (Material)	
ACABADO (Finish)		ACABADO (Finish)	
NOMENCLATURA (Description)		NOMENCLATURA (Description)	
SLD LADDER		SLD LADDER	

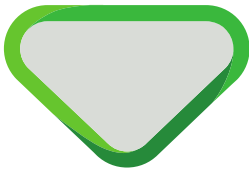

liftinstituut
SINCE 1933

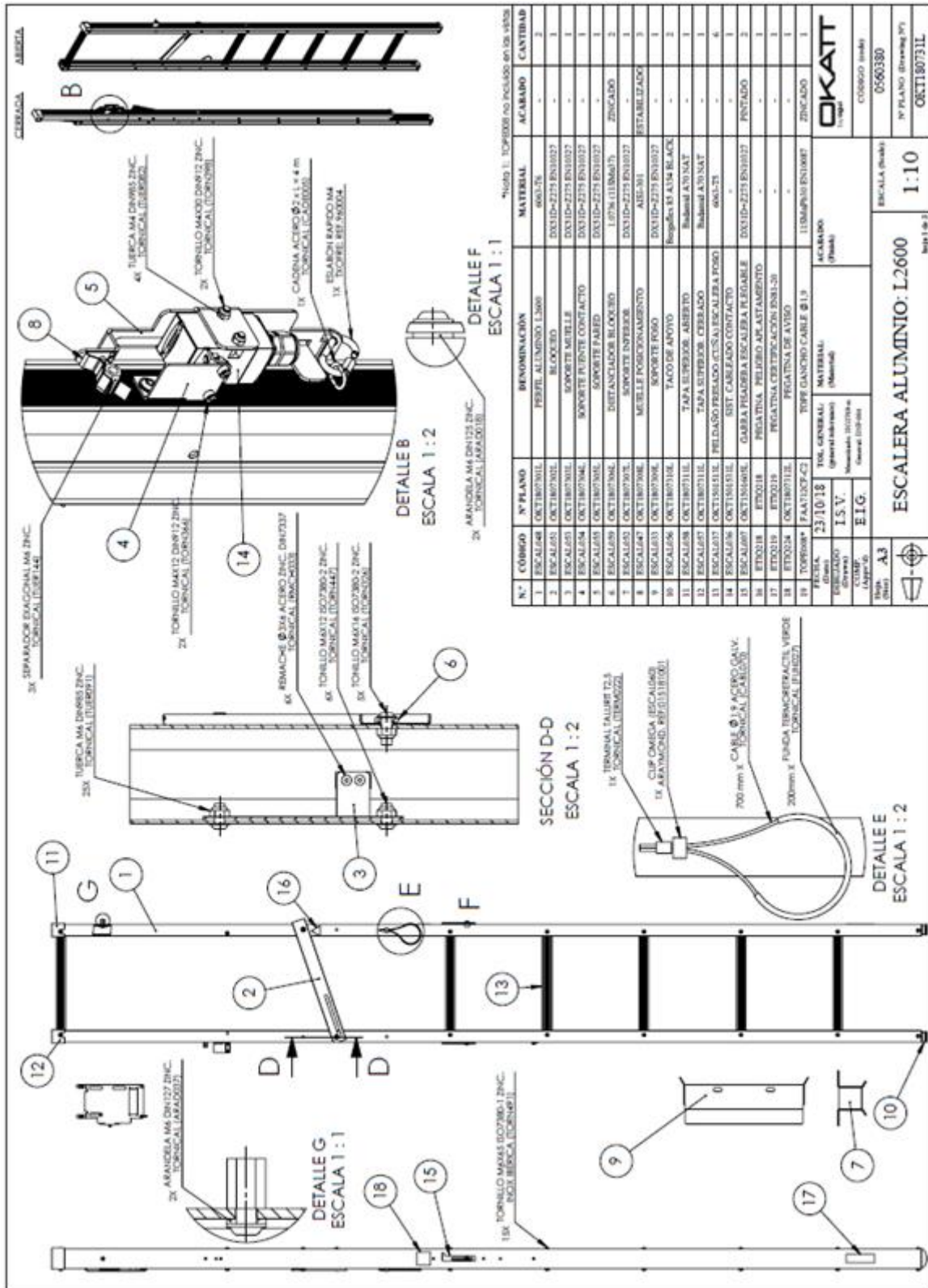

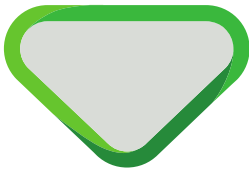

liftinstituut
SINCE 1933

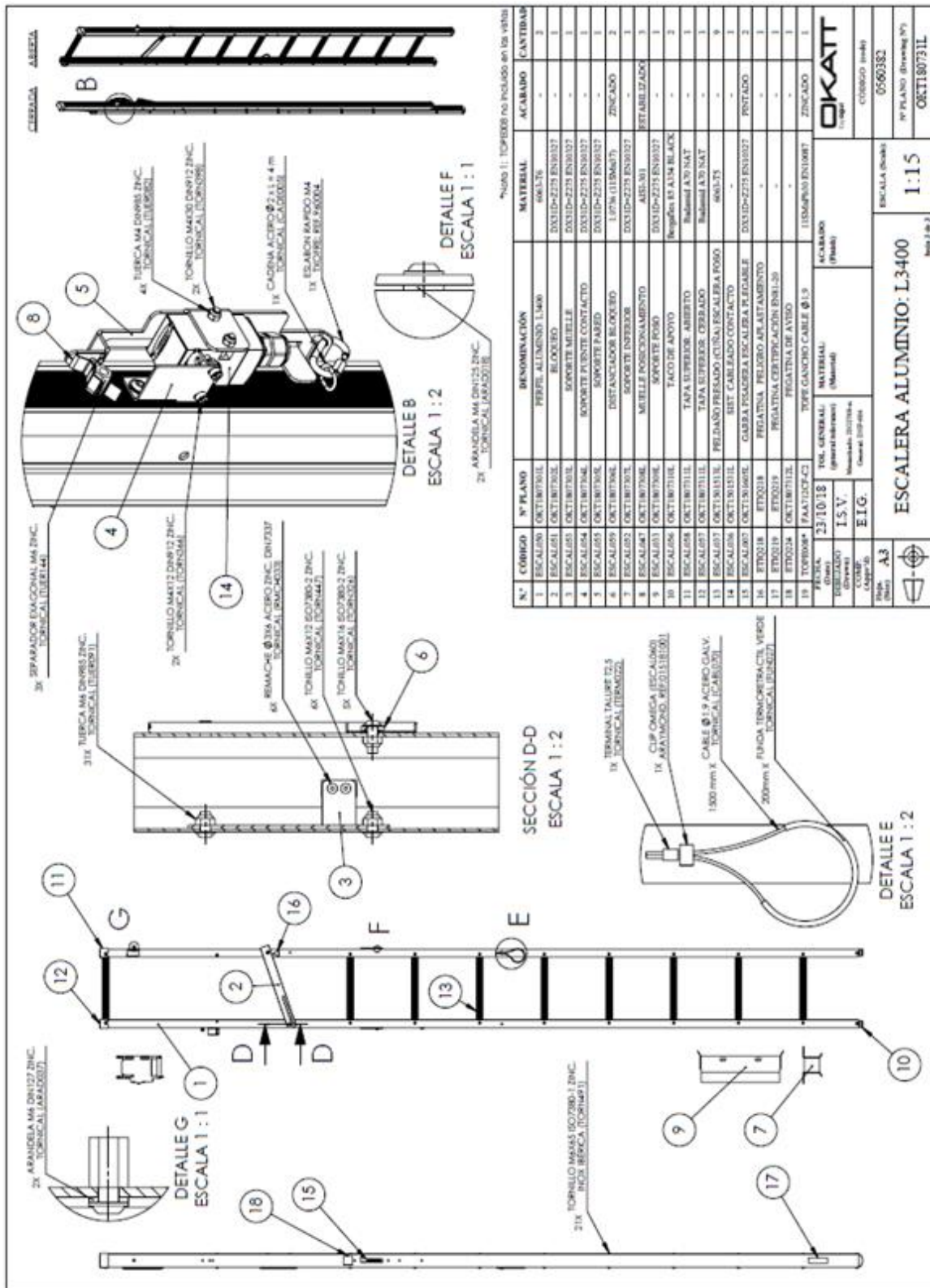

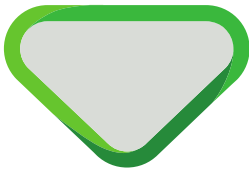

LADDER TYPE 2A

Model	L1 (mm)	L2 (mm)	L3 (mm)	L4 (mm)	N steps	Pit Height (mm)	Ladder	Profile	Safety Switch
Mod.1	2000	480			2	500-610	1 piece	Profile 1	INC/INO
Mod.2	2000	770	355	39	3	611-900			
Mod.3	2450	1060			4	901-1190	2 pieces	Profile 3	
Mod.4	2450	1350			5	1191-1350			
Mod.5	3150	1350			5	1351-1480			
Mod.6	3150	1640	360	45	6	1481-1770			
Mod.7	3150	1930			7	1771-2050			
Mod.8	3400	2220		65	8	2050-2300			

PROFILE 1 Scale 1:2

PROFILE 3 Scale 1:2

Tolerancia general mecanizada (mm)		Max. de surcos		L.P.P.		1000	
General tolerance machined (mm)		Up to		6		400	
		=		0.1		0.3	
				0.5		1.2	

Tolerancia general según DNP-004 / General tolerance according to DNP-004

2					
1					
0	Edición (Edition)	30/01/18	E.I.G.	I.S.V.	
Rev.	MODIFICACIONES (Changes)		FECHA (Date)	COMP. (Appr.)	REB. (Drawn)

MATERIAL (Material)		OKATT
ACABADO (Finish)		
DENOMINACION (Description)		
Ladder type 2: Models		
Nº PLANO (Drawing No)		
OKT180121L		
ESCALA (Scale): 1:20		

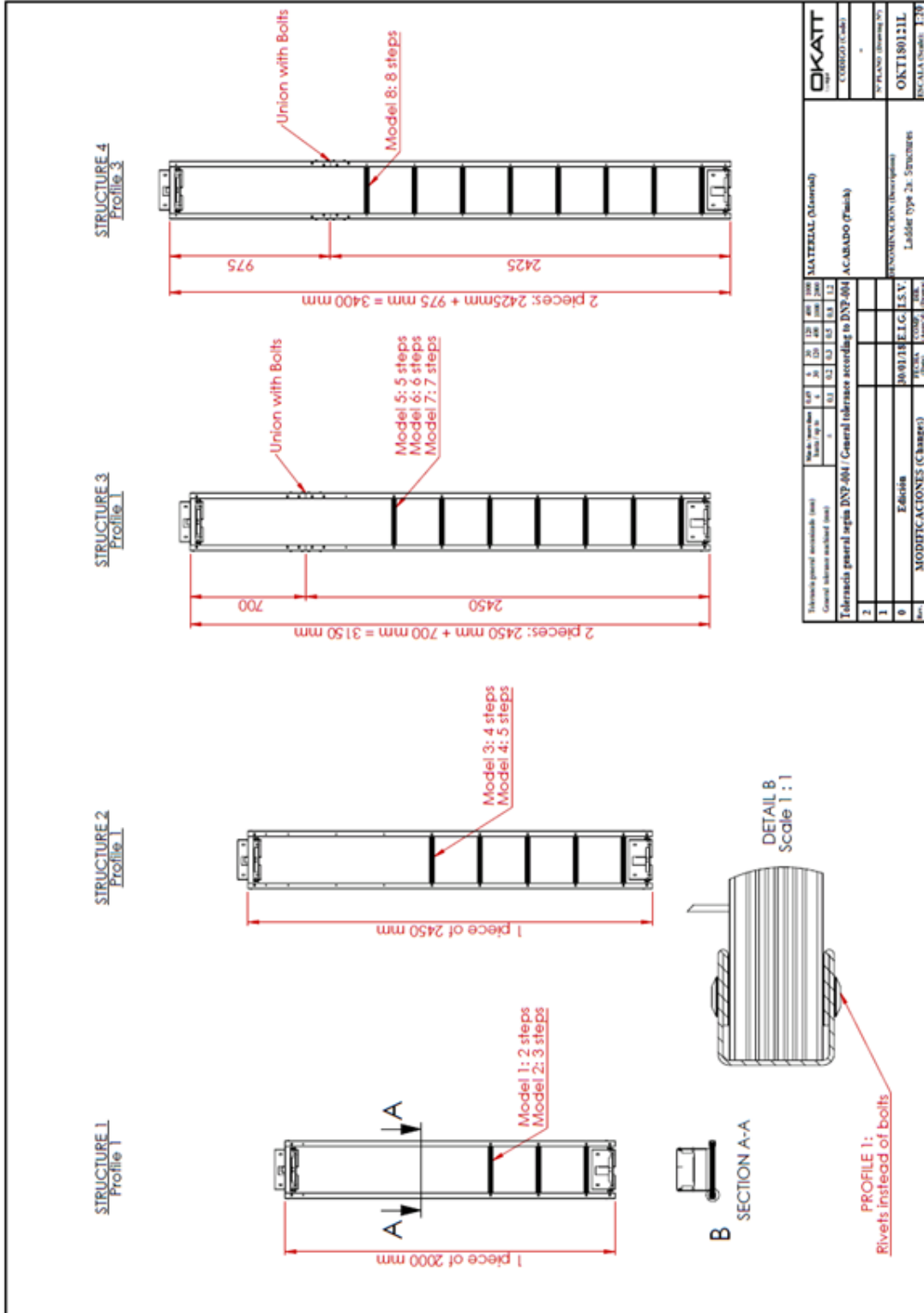
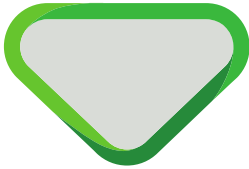



liftinstituut
SINCE 1933

LADDER TYPE 2B

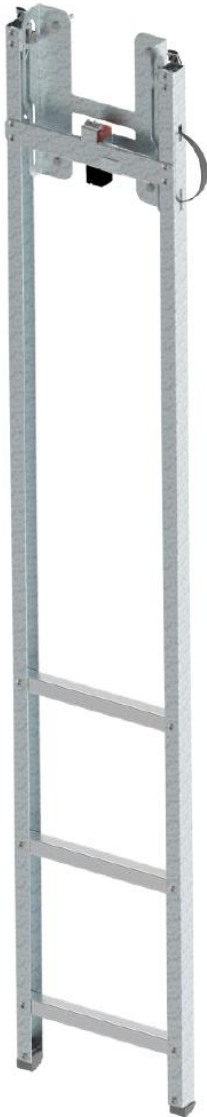

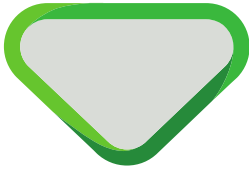

liftinstituut
SINCE 1933

GENERAL MODELS

PACKED IN TWO PARTS

DETAILLE S
ESCALA 1:2

Labels in drawing: RMCH041 (On both sides), LADDER STINGER, STEP, 47, 329, S

CÓDIGO	L (mm)	Total Weight (Kg)	Movable Weight (Kg)	Altura Foso (mm)
B050	1845	6.61	5.58	500-680
B100	2135	7.46	6.43	681-960
B200	2425	8.32	7.39	961-1241
B300	2815	13.09	12.06	1252-1618
B400	3105	14.23	13.20	1619-1900

FECHA DE EMISIÓN (Date)	25/05/2021	TOL. GENERAL: (general tolerance)	MATERIAL: (Material)	ACABADO: (Finish)	OKATT
DIBUJADO (Drawn)	E.P.A.	Modificado: 15/02/2016	General: 25/05/06		
COMÉ. (Author)	E.I.G.	2B TYPE LADDER		ESCALA (Scale):	1:10
NO. (Sheet)	A3			Nº PLANO (Drawing No)	OKT210101L

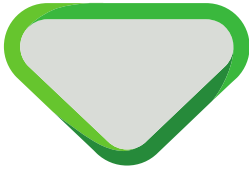

liftinstituut
SINCE 1933

ONLY RELEVANT FOR B300 AND B400 MODELS

DETAILLE K
ESCALA 1:2

DETAILLE L
ESCALA 1:2

COMPLEMENT ASSEMBLY

FECHA (Date)	25/05/2021	TIT. GENERAL (general tolerance)	General: DIN-208	ACABADO (Finish)	OKATT by type
DISEÑO (Design)	E.P.A.	MATERIAL (Material)			
COMP. (Appr.)	E.I.G.				
Revisión (Rev)	A3				
				ESCALA (Scale)	1:10
				Nº PLANO (Drawing Nº)	OKT210101
				COBIGO (code)	
				2B TYPE LADDER	

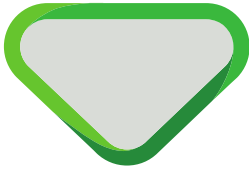

liftinstituut
SINCE 1933

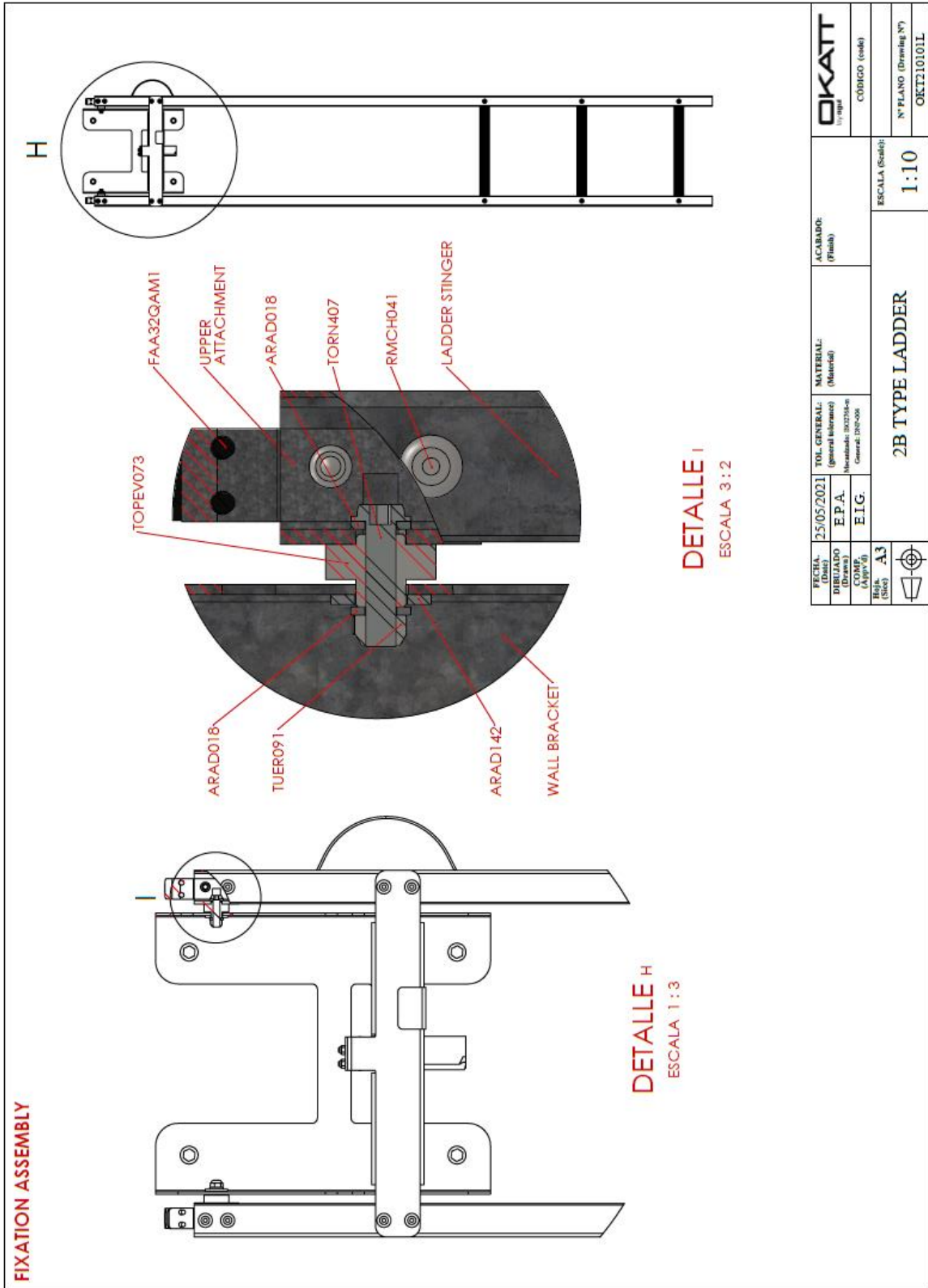

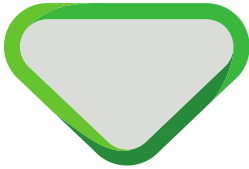

liftinstituut

SINCE 1933

Annex 2 Documents of the Technical File which were subject of the examination

Title	Document number	Date
TEST REPORT	C/170589I1	13-03-2017
TEST REPORT	C/172550I1	29-09-2017
TEST REPORT	C/180508I1	14-02-2018
TEST REPORT	C/183215I1	09-11-2018
TEST REPORT	C/183423I1	20-11-2018

Annex 3. Reviewed deviations from the standards

EN xx-x par.	Requirement	Accepted design
x.x.x		

Annex 4 Revision of the certificate and its report

Rev.:	Date	Summary of revision
-	22-11-2016	Original
1	21-03-2017	L260, L315, L340 and L4000 added
2	13-03-2018	New description Foldable pit ladder Type 3A, pit ladder Type 2A and L050 added
3	04-12-2018	Inclusion of aluminium ladders L260A, L315A and L340A now also made of the aluminium
4	08-06-2021	New ladder 2B, EN 81-20:2020, EN 81-21:2018 and elongation for 5 years