

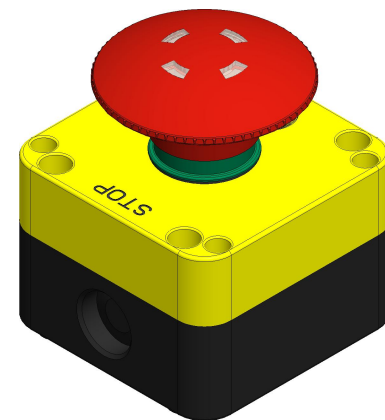

SCALA 0.500

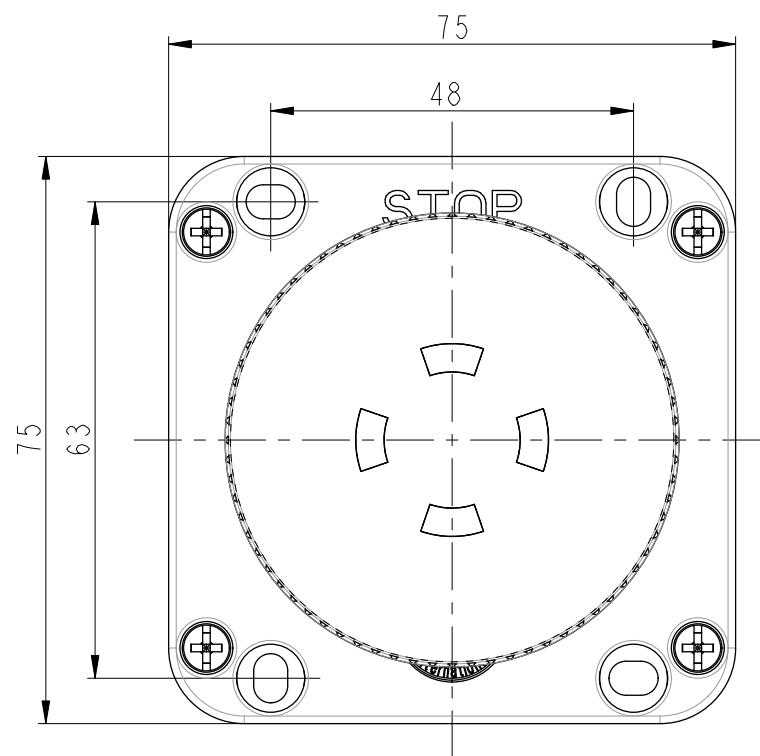

SCALA 0.500

POS.	DESCRIZIONE	DESCRIPTION	COD.	Q.TY
9	VITE AUTOF. PARZ. TC+/- M4X30 1022 GEO.	SCREW TAPPING PAN HEAD+/- M4X30 1022 GEO.	11606022	4
8	PULSANTE FUNGO P/P VIS D.60	PUSH BUTTON MUSHROOM P/P VIS D.60	PPFNIP6SH	1
7	PORTAELEMENTI DA QUADRO A LEVA RIDOTTO	COUPLING PLATE REDUCED	PPELN8-R	1
6	GUARNIZ PER PULSANTE DA QUADRO	PUSH BUTTON PANEL SEAL	11708202	1
5	GHIERA FILETTATA M22xI IN ZAMA	M22xI ZAMA LOCK NUTS	11705100	1
4	CORDA GOMMA D2E5X280	GASKET	11901028	1
3	COPERCHIO PQ01 TAMPOGRAFATO "STOP"	PRINTED PQ01 COVER "STOP"	20101198	1
2	CONTATTO AUTOMONITORATO NO-NC-NO	SELF-MONITORED CONTACT NO-NC-NO	PCW010SS	1
1	CASS Q03-Q04 I FORO IM16 IM20	BOX	11710078	1

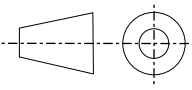
EDIZIONE / EDITION	DATA / DATE	MODIFICA / MODIFICATION	PRESCRIZIONE DI ISPEZIONE / PRESCRIPTION OF INSPECTION	LIVELLO / LEVEL	AQL																								
-	20-01-20	EMMISSIONE	Visivo / Visual	I	25																								
MODIFICATO DA - MODIFIED BY		Magni, Roberto	Quota critica / Critique Dimension	II	1																								
			Altre quote / Other Dimensions	I	25																								
 GIOVENZANA INTERNATIONAL B.V. Strawinskylaan 1105 1077 XX Amsterdam - NL		FINITURA / FINISH																											
DENOMINAZIONE / DESCRIPTION		MATERIALE / MATERIAL	FOGLIO / SHEET																										
DISPOSITIVO PQ01 EMERG P/P D60MM SS			I/1																										
DISPOSAL PQ01 EMERG P/P D60MM SS			SCALA/SCALE DATA/DATE																										
DIM. INGOMBRO L x H x P		PESO / WEIGHT (g)	STAMPO / MOULD N°	FIGURE N°/CAVITY N°	AVANZAMENTO/STATUS																								
75.0 x 87.5 x 75.0		--	-	0	Esecutivo																								
Tolleranza		Dimensioni Nominali / Nominal Dimensions			DISEGNO / DRAWING N°																								
Tolerance		<table border="1"> <tr> <td>>0,5</td> <td>>6</td> <td>>30</td> <td>>120</td> <td>>315</td> <td>>1000</td> <td>>2000</td> <td>>4000</td> </tr> <tr> <td>..6</td> <td>..30</td> <td>..120</td> <td>..315</td> <td>..1000</td> <td>..2000</td> <td>..4000</td> <td></td> </tr> <tr> <td>±0,05</td> <td>±0,1</td> <td>±0,2</td> <td>±0,5</td> <td>±0,8</td> <td>±1,2</td> <td>±2,0</td> <td>±3,0</td> </tr> </table>			>0,5	>6	>30	>120	>315	>1000	>2000	>4000	..6	..30	..120	..315	..1000	..2000	..4000		±0,05	±0,1	±0,2	±0,5	±0,8	±1,2	±2,0	±3,0	REVISION
>0,5	>6	>30	>120	>315	>1000	>2000	>4000																						
..6	..30	..120	..315	..1000	..2000	..4000																							
±0,05	±0,1	±0,2	±0,5	±0,8	±1,2	±2,0	±3,0																						
		PQ01P6S/SS			-																								