

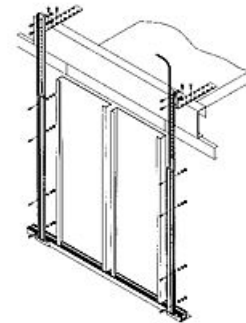

PEW Electrical Distributors



PEW REF: 616800005



Static Kit Installation diagram

Installation Kit i 616 800-010 for installing a set of 9mm to 15mm profile detectors in a fixed position at either end of the lift car sill

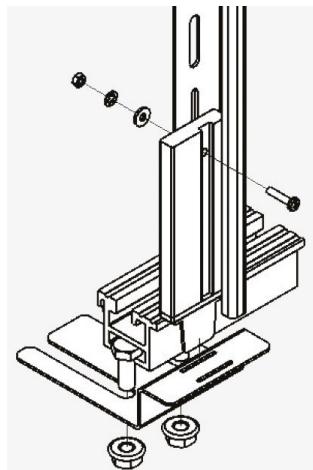

Sill Bracket attached to car sill

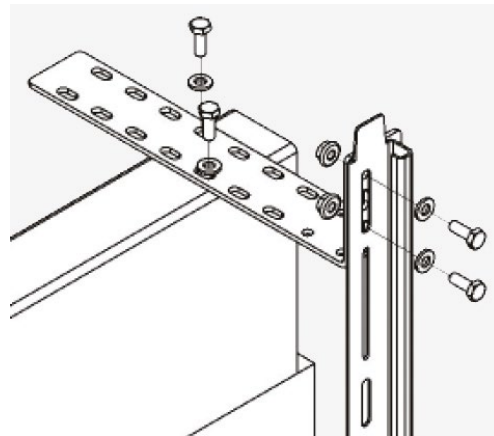

Short 'L' Bracket attached to Long Bracket

Long Bracket

This Long Bracket is effectively used to support the detector and increase its overall length so that it can be secured to the top of the lift car. The detector is secured to the Long Bracket by using the M3.5 nuts, bolts and washers provided in the fixing kit.

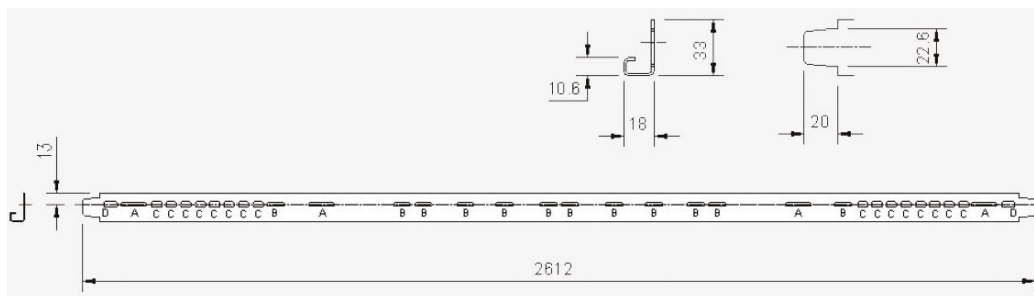

PEW Electrical Distributors Ltd

Unit 1 The iO Centre
59-71 River Road
Barking, Essex IG11 0DR

0208 507 1001

sales@pewelectrical.com
www.pewelectrical.com

