



PEW Electrical
Distributors

CTC17 - Car Top Control

Application

The car top control provides easy control of the lift car, including stopping all calls and movement.

Choose from pre-wired and non-wired versions.

Technical Details

All buttons, switches and Emergency stop

Approvals: CE, EN50007 IEC/EN60947-5-1 Rated Voltage: 690V

Water Resistance: IP65 (Button pressel only)

Terminal strip

Approvals: DE, EN60127-6

Rated Voltage: 500V

Twin Passive RCD (Residual Current Device) Socket

Rated Voltage: 230V

Trip rating: 30mA

Approvals: BS1363, BS7288

LED (Light Emitting Diode) surface mounted Emergency bulkhead light

Power consumption: 3 Watt

Colour: 6500K

Water Resistance: IP65

Approval: CE

Din rail terminals

Rated wire cross section: 2.5mm

Colour: Beige

Rated Voltage: 400V

Approvals: UL, cUL, KEMA KUR, EAC

Internal wiring

Type: H05V-K 2491X

Cable Diameter: 1.5mm

Rated Voltage: 300/500V

Insulation: PVC (Polyvinyl Chloride)

Approvals: EN50525-2-31, EN60228 BASEC

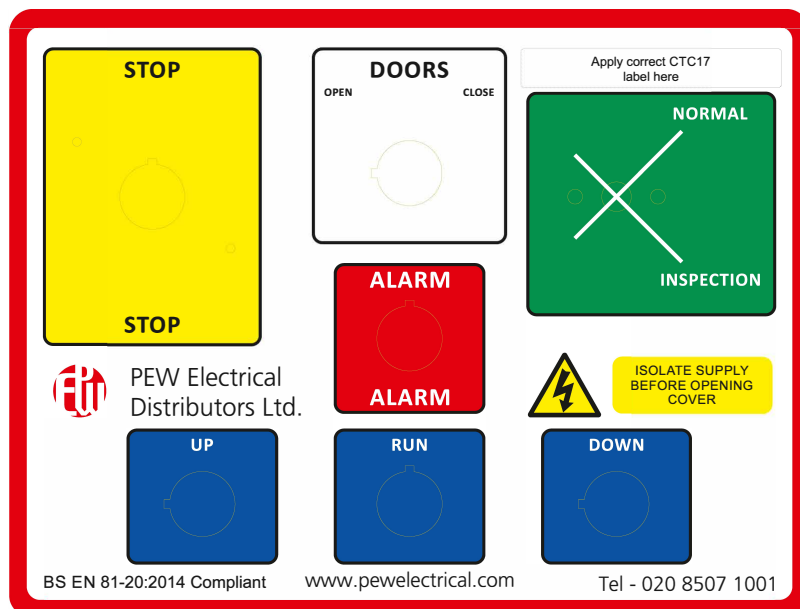

Dimensions

D - 205mm

W - 280mm

H - 285mm

Weight - 5.04Kg*

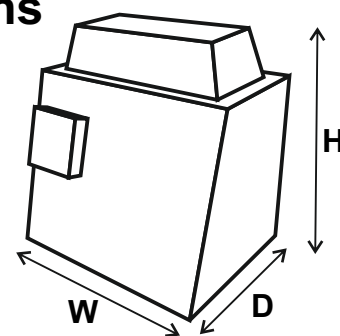

Standards

BS7255:2012 and EN81-20

